

THINK  
LOOK  
FEEL  
ABSORB  
DECIDE  
INDULGE

AS PER AN ESTIMATE BY THE CREATOR OF THE FINE ART FUND, PHILLIP HOFFMAN, THE SIZE OF THE INDIAN ART MARKET HAS GROWN FROM \$2 MILLION TO APPROXIMATELY \$400 MILLION IN THE LAST FIVE YEARS. AND NOT ONLY ARE THE TYEB MEHTAS AND MF HUSAINS IN DEMAND, EVEN EMERGING ARTISTS ARE CATCHING THE EYE OF COLLECTOR.

## The &. Story

Five years ago, three Miami collegians, Vikas Johari, Jorge Aranz and Paul Lichtenegger, banged their ingenious heads together to shake up the world of intellectual luxury reading. They had a dream: to make the thinking minds of the world sit up and take notice of their innovative ideas. And thus was born &. or ANDPERSAND. For four years and through 49 issues, ANDPERSAND has been dusting the creative cobwebs.

**The name:** The name 'and' has been conceived under the philosophy that there's always more. The best way to unite two things – even polar opposites – is to place the word 'and' in between them. We believe and is the medium to connect our readers with the outside world.

LUXURY art

On its 50th anniversary, &. takes a leap forward to match moods with the ever changing creative stream. We marry art and luxury to become India's only magazine to do so.

# 5 years of &

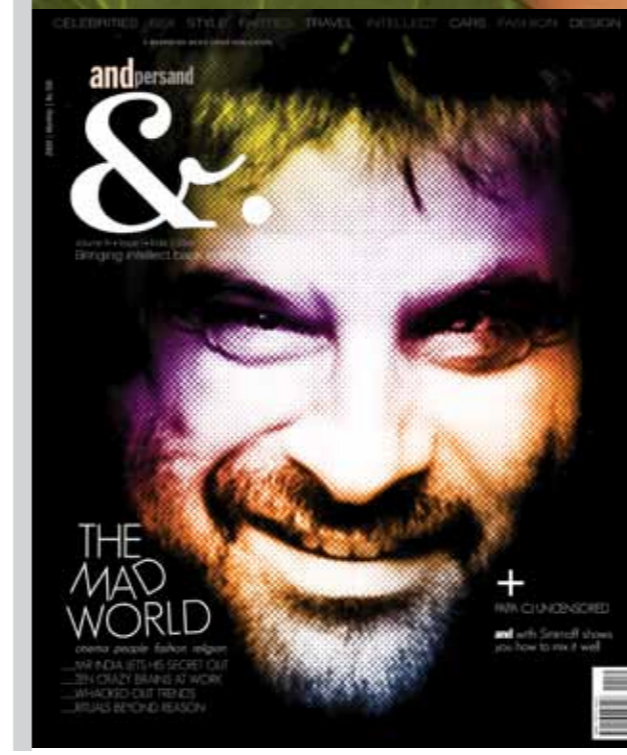
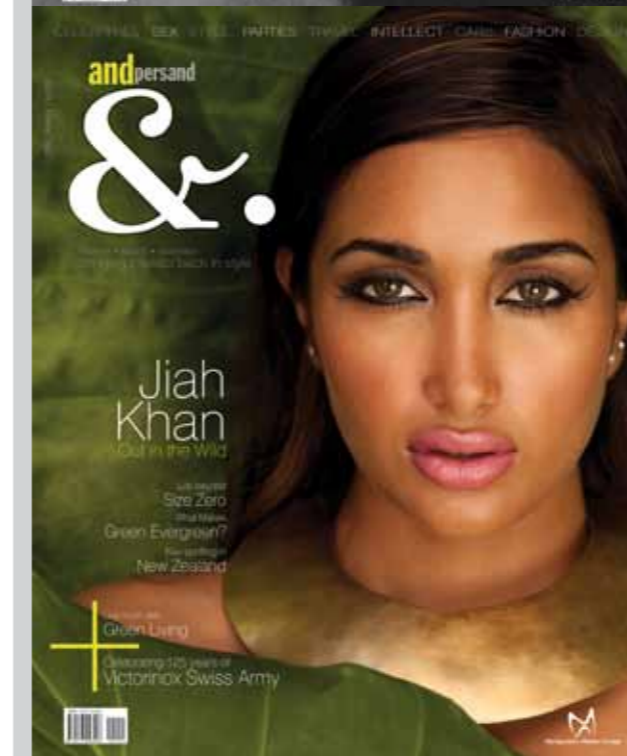
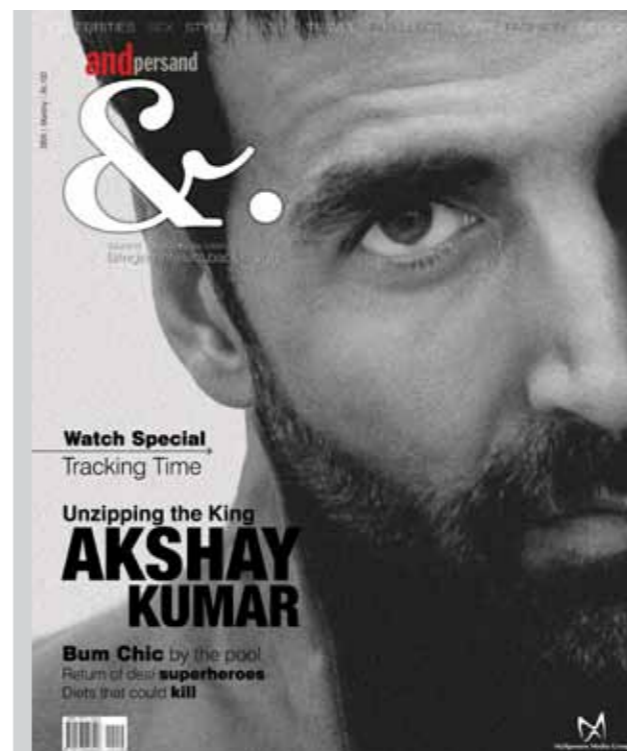

6 issues a year  
edgy themes

► favourite art hotels from across the country

► 32 young creative minds across genres

► India's top 10 luxurious green ideas

► 10 top designer houses on sale

► best of the best of &c.

► 20 virgin locales from across the world

*'This is one magazine I have to be on the cover of. I love the international presentation and the feel of it. It's the only magazine that I actually keep because of the quality of the editorial content.'*

**Feroze Gujral, Designer**

FEB-MARCH

**TOP 10 ART HOTELS**

We get a few jet setters to choose their favourite Art Hotels from across the country. Our panelists include the grand dame of fashion Ritu Kumar, Deepika Jindal, the brain behind luxury steel design Artdinox, dancer with a cause Mallika Sarabhai and Satya Bagla, MD, Exclusive Motors, the company that sells dream wheels like Bentley, Lamborghini and Bugatti.

AUG-SEPT

**DESIGN AND ARCHITECTURE**

With the anniversary issue, we salute the best from various fields. From the most creative artist, the trip of a lifetime to the most opulent hotel and the spiciest restaurant and men and women who have impressed us, AND selects the best of the best.

APRIL-MAY

**32 EMERGING ARTISTS**

A product designer who believes a chair should speak its mind when the user has sat on it for an unhealthy long time; a drummer who teaches CEOs to drum out their stress and an author who doesn't write... we hunt for 32 young creative minds across genres. The only qualifying condition: banish boundaries!

OCT-NOV

**DESIGN AND ARCHITECTURE**

We showcase 10 top designer residential spaces from across the country. From vintage boutique homes to artistic housing complexes designed by European design masters, we bring you the chickest of homes. The catch is, they are up for sale!

JUNE-JULY

**GREEN**

We choose 10 of India's most luxurious green ideas. For those who think being eco-friendly can't be lavish, this section will be an eye-opener with luxurious office spaces, plush homes and living ideas that talk luxe.

DEC-JAN

**FOOD AND TRAVEL**

You would have never heard of this beach, never seen an image of this mountain or read a review of this restaurant. AND discovers 20 virgin locales from across the world.



living | chic  
minds | trend | curator  
earth | voyage  
awakening  
gallery | connoisseur  
wheels | indulge

## OUR SECTIONS



- & SHOWCASE | This is the main feature of the magazine and will deal with a special theme every issue, like travel, hotel, fine dining, discovering young talent and environment.
- LIVING | lifestyle trends, people and places, luxury brands and concepts.
- MINDS | this is a Q&A section that will delve into the minds and lives of artists and the creative brigade.
- & TREND | will track emerging trends in the world of art and design
- CURATOR'S CORNER | the curator speaks about his pet gallery and exhibition
- & INSIDER | expert column on how to buy art, sell art or just appreciate art
- EARTH | green soul of the magazine
- GALLERY | an image gallery (can be shot or procured involving galleries, lifestyle brands and artists)
- VOYAGE/HOP | travel both within the country and international
- WHEELS | automobiles to splurge on
- CONNOISSEUR | the latest fine dining trends, places to dine, star chefs
- AWAKENING | a social cause that has stirred us
- HAPPENINGS | events from around the country
- CHIC | forecasting fashion and style trends
- INDULGE | luxury products you must buy



# TECHNICAL SPECIFICATIONS

	W X H (inch)	W X H (inch)	W X H (inch)
	8.5" X 11"	215 X 26.5	215 X 265
Live/ Safe Area	7.9" X 10.4"	20 X 26.5	200 X 265

Bleed ad Dimensions	W X H (inch)	W X H (inch)	W X H (inch)
Full Page	8.7 X 11.2	22 X 28.45	220 X 284.5
Spread	17.4 X 11.2	44 X 28.45	440 X 284.5

Non-Bleed Dimensions	W X H (inch)	W X H (inch)	W X H (inch)
Full Page	7.7 X 10.2	41 X 26	195 X 260
Spread	16.15 X 10.2	19.5 X 26	410 X 260

GSM	Cover 300 gsm	Inside Pages 100 gsm
Periodicity	Bi Monthly	
Print Run	60,000 Copies	

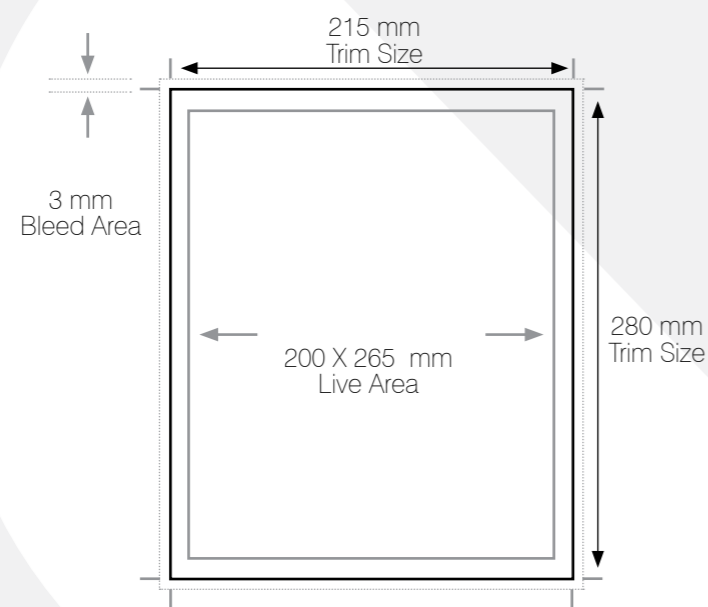

# &. RATE CARD

RATE CARD	
Full Page	2,25,000
Double spread	4,50,000
Inside Back	4,00,000
Back	5,50,000

All rates in INR per issue

CREATIVE DEADLINE	
ISSUE	DEADLINE
Jan-Feb	10th Dec
April-May	10th March
June -July	10th May
Aug-Sep	10th July
Oct-Nov	10th Sep
Dec-Jan	10th Nov

...and similarly for all successive months

